



GENUINE PARTS

INSTALLATION INSTRUCTIONS

DESCRIPTION:	Roof Cross Bar Kit
APPLICATION:	Rogue
PART NUMBER:	Roof Cross Bar Kit (999R1 G2500)

KIT CONTENTS:

Item	Qty.	Part Description	Service Part Number
A	1	Cross Bar - Front	999R1 G2507
B	1	Cross Bar - Rear	999R1 G2508
C	8	M6 Torx Bolt - 26 MM Long	999R1 XZ500-S1
D	1	T30 Torx Wrench	N/A
E	1	Installation Instruction Replacement Template	999V2 AW000

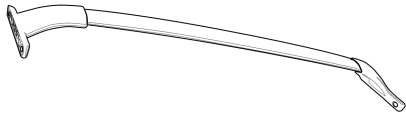

A, B



C



D



E

TOOLS REQUIRED:

None.

PRE-INSTALLATION WARNINGS, CAUTIONS, CRITICAL STEPS, and NOTES:

- Dealer Installation Recommended. Instructions may refer to Service Manual.
- Removal and Re-Installation of Cross Bars requires purchase of new M6 bolts (999R1 XZ500-S1) or the re-application of Thread locking adhesive such as LOCTITE® 242® or equivalent.
- Do not attempt to adjust fasteners on the underside of the brackets. Fasteners are pre-adjusted to the proper torque requirement by the manufacturer.

INSTALLATION PROCEDURE:

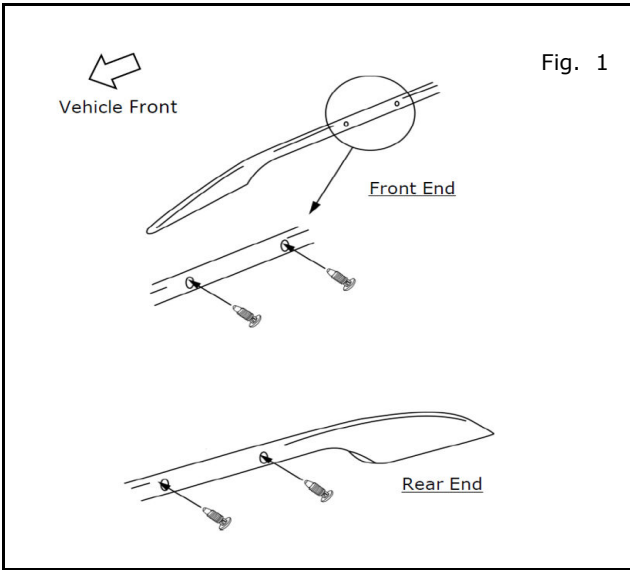

- If plastic plugs are installed in roof rail, Please Uninstall plastic plugs in roof rails as shown in Fig.1.

NOTE:

Stow plastic plugs for future use if crossbars will be removed.

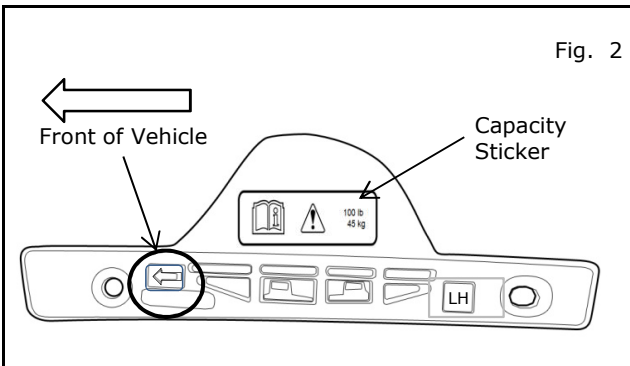

CAUTION

- **Make sure sunroof is in closed position during installation process.**

- Arrow points forward.

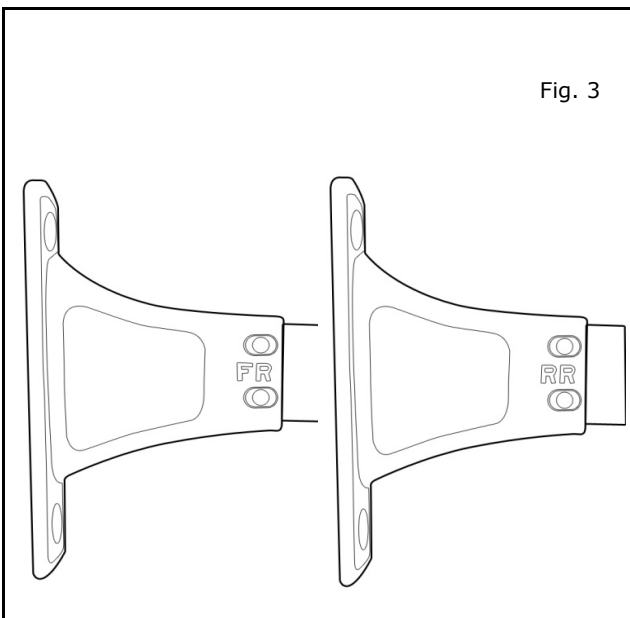

- Each cross bar marked with "FR" or "RR".
- Front (FR) cross bar installed on side rail in front of rear doors.
- Rear (RR) cross bar installed on side rail behind rear doors.

INSTALLATION PROCEDURE:

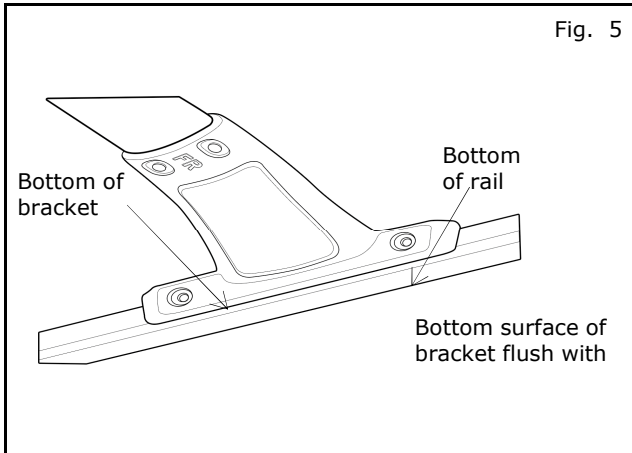
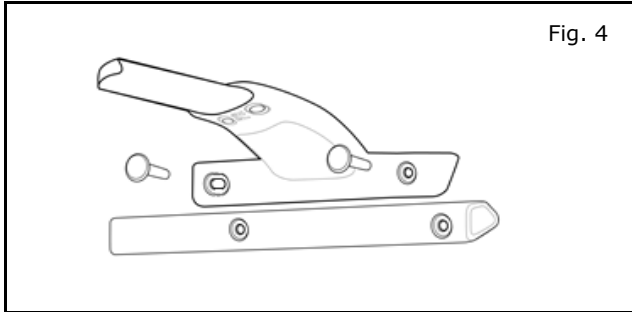

CAUTION

- **Protect painted area on the vehicle roof under crossbars by placing a piece of cloth under crossbars to prevent scratch damage.**

Make sure that cross bar is properly in place on side rail with attaching holes / slots positioned over rivet nuts before tightening to specifications. 8-9N-m (71-80 in-lbs)

- 1) Loosely install all 4 bolts on front (FR) cross bar.
- 2) Secure forward bolt on driver side first and then secure remaining 3 bolts to proper torque (Fig 4).
- 3) Repeat procedure for rear (RR) cross bar.
- 4) make sure that bottom surface of cross bar bracket is flush with bottom surface of side rail prior to tightening bolts (Fig 5).
- 5) Place TORX key and instruction template in polybag and keep in vehicle glove box.